

## Ultra Wide Band AC Low Noise Amplifier 0.08GHz-6GHz



Note: Photo is for illustration purposes only.  
Please refer to outline drawing.

### Product Description

RAMP00M06G is an ultra wide band AC powered low noise amplifier with a frequency range of 0.08 to 6GHz.

The power output of this amplifier is 26dBm typical. The typical gain is 52 dB with a gain flatness of  $\pm 2.5$ dB.

The AC power amplifier uses a standard convenient 110V/220 VAC power supply.

### Features

- Ultra Wide Band AC Low Noise Amplifier
- Gain 52dB Typical
- P1dB Output Power 26dBm Typical
- Supply Voltage 110/220 VAC
- 50 Ohm Matched Input / Output

### Typical Applications

- Wireless Infrastructure
- Military and Aerospace Applications
- Test Instrumentation
- Radar Systems
- 5G Wireless Communications
- Microwave Radio Systems
- TR Modules
- Research and Development
- Cellular Base Stations

### Electrical Specifications (T<sub>A</sub>=+25°C)

Parameter	Min	Typ	Max	Min	Typ	Max	Units
Frequency Range	0.08		3	3		6	GHz
Gain	48	52	56	46	50	56	dB
Gain Flatness		$\pm 1.5$	$\pm 2.5$		$\pm 1.5$	$\pm 2.5$	dB
Gain Variation Over Temperature (-40°C~+85°C)		$\pm 1.0$			$\pm 2.0$		dB
Noise Figure		2.5	4.5		3.0	4.5	dB
Input VSWR		2.0	2.5		1.8	2.2	: 1
Output VSWR		1.5	2.0		1.8	2.2	: 1
Output 1dB Compression Point (P1dB)	24	26		23	26		dBm
Saturated Output Power (P <sub>sat</sub> )		28			27		dBm
Output Third Order Intercept (OIP3)		32			32		dBm
Isolation S12			-65				dB
Supply Current (AC=220V)			60				mA
Weight			2.49 Max.				lbs.
Impedance			50				Ohms
Input / Output Connectors						SMA-Female	
Package						Epoxy Sealed (Standard) Hermetically Sealed (Optional)	

**Absolute Maximum Ratings**

Parameter	Rating
Supply Voltage Range	110 to 240 VAC
*RF Input Power (RFIN)	-16dBm

**Bias Up Procedure**

1. Connect input and output with 50 Ohm source and load with in band return loss better than 10dB.
2. Connect AC Plug
3. Flip switch to "ON" position

**Bias Down Procedure**

1. Flip switch to "OFF" position
2. Remove AC Plug
3. Remove RF Connection

**Environmental Specifications and Test Standards**

Parameter	Description
Operational Temperature	-40°C to +85°C (Case Temperature)
Storage Temperature	-50°C to +105°C
Thermal Shock	-40°C → +85°C (5 Cycles / 10 hours)
**Random Vibration	MIL-STD-202G Table 214-I, Test Condition Letter C 1.5 Hours Per Axis
High Temperature Burn In	Temperature +85°C for 72 Hours
Shock	1. Weight >20g, 50g half sine wave for 11ms, Speed variation 3.44m/s 2. Weight <=20g, 100g Half sine wave for 6ms, Speed variation 3.75m/s 3. Total 18 times (6 directions, 3 repetitions per direction).
Altitude	Standard: 30,000 Ft (Epoxy Sealed Controlled Environment) Optional: Hermetically Sealed (60,000 ft. 1.0 PSI min)
Hermetically Sealed (Optional)	MIL-STD-883 (For Hermetically Sealed Units)

\*Maximum RF input power is set to assure safety of amplifier. Input power may be increased at own risk to achieve full power of amplifier. Please reference gain and power curves.

\*\*For vibration testing details please see additional information section.

**Typical Performance Plots**

**Gain @+25°C**

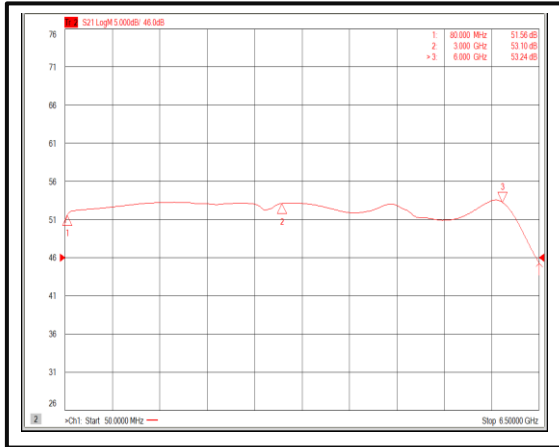

**Input VSWR @+25°C**

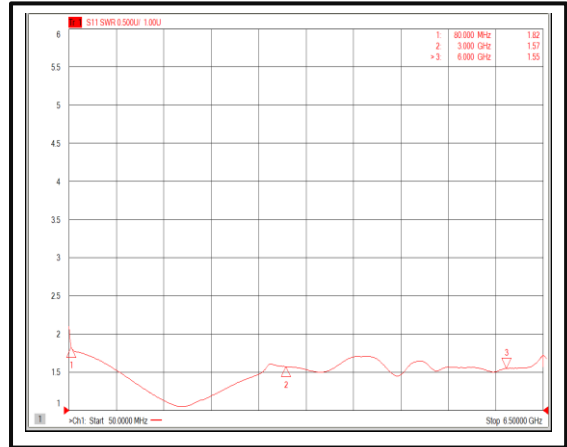

**Output VSWR @+25°C**

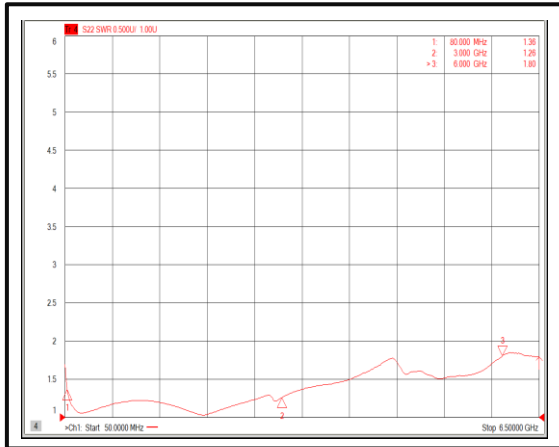

**Isolation @+25°C**

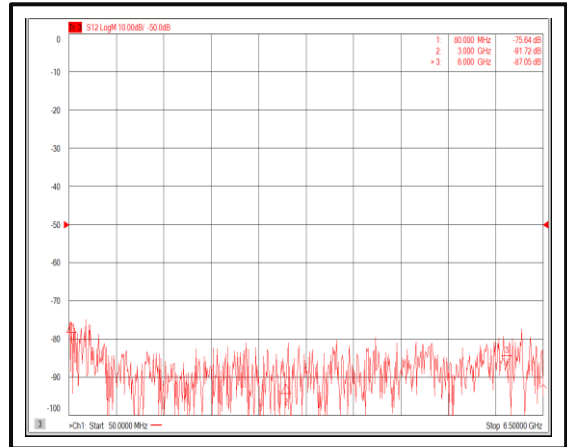

**Gain @-40°C**

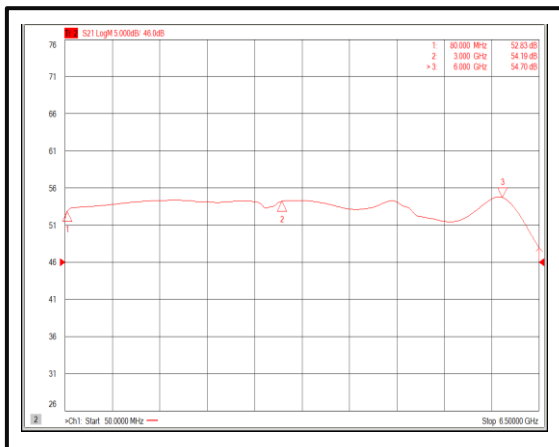

**Input VSWR @-40°C**

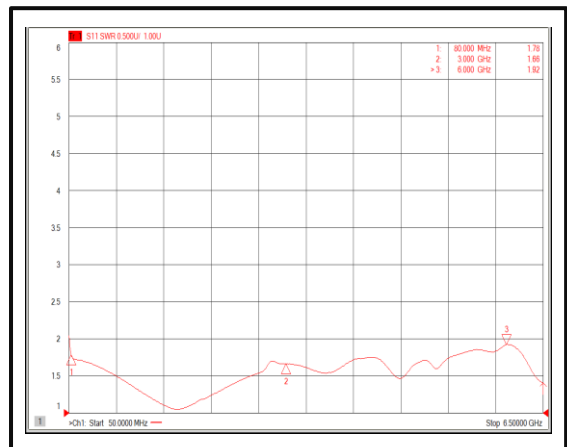

Note: Small signal VNA measurements include attenuators to protect equipment

Typical Performance Plots

Output VSWR @-40°C

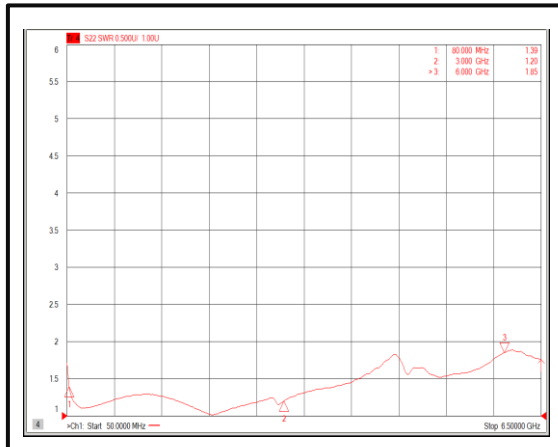

Isolation @-40°C

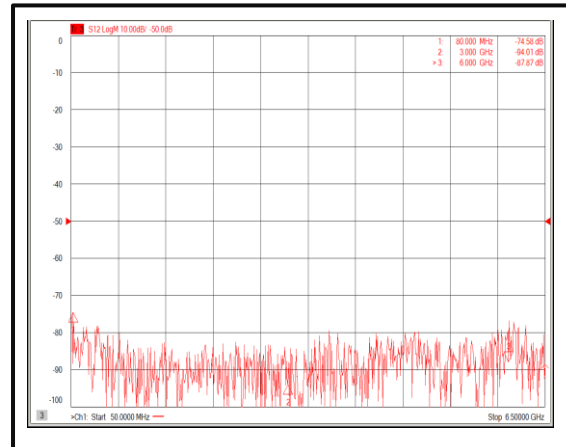

Gain @+85°C

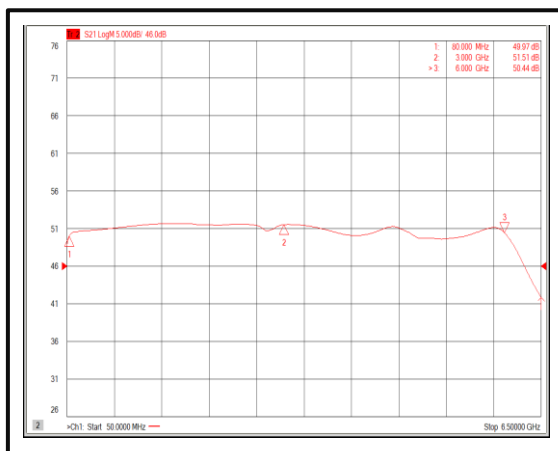

Input VSWR @+85°C

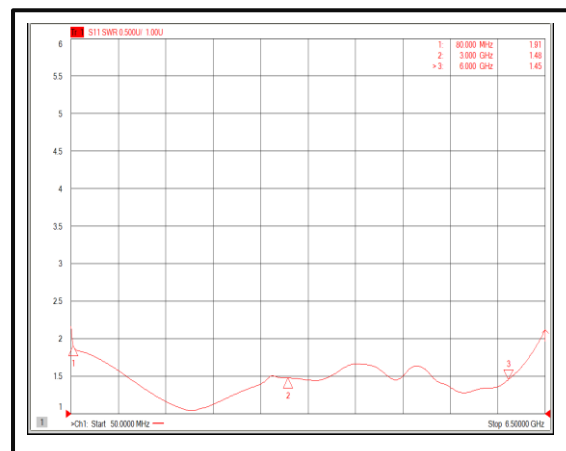

Output VSWR @+85°C

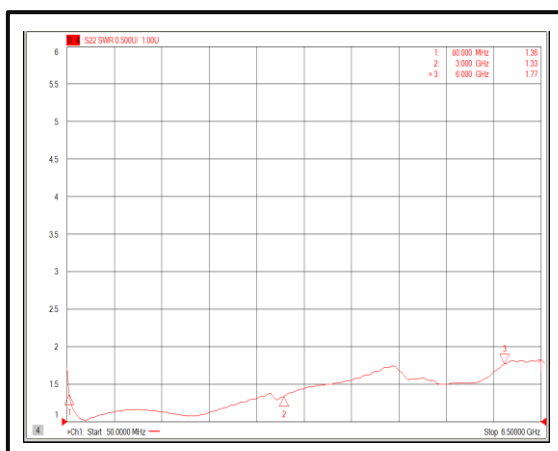

Isolation @+85°C

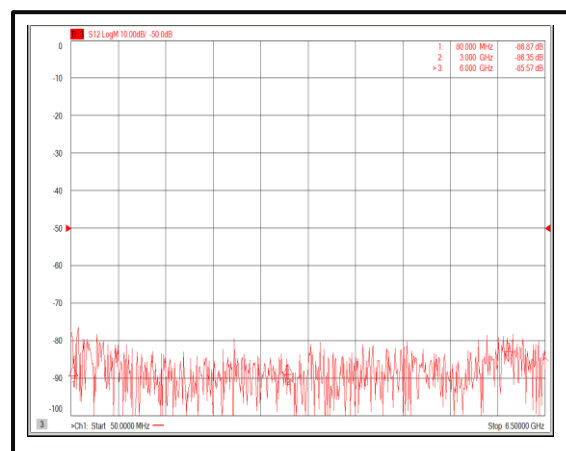

Note: Small signal VNA measurements include attenuators to protect equipment

Typical Performance Plots

Gain vs. Output Power

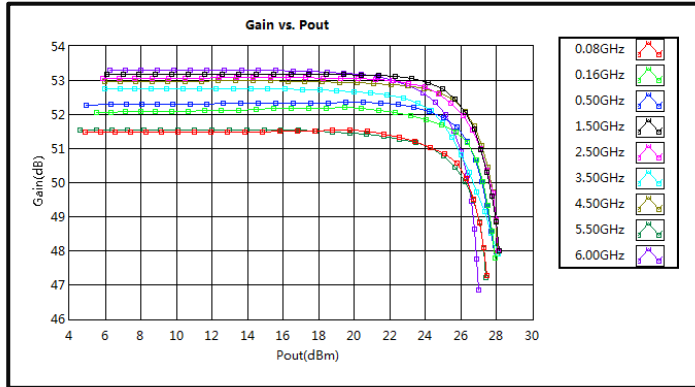

PndB vs. Frequency

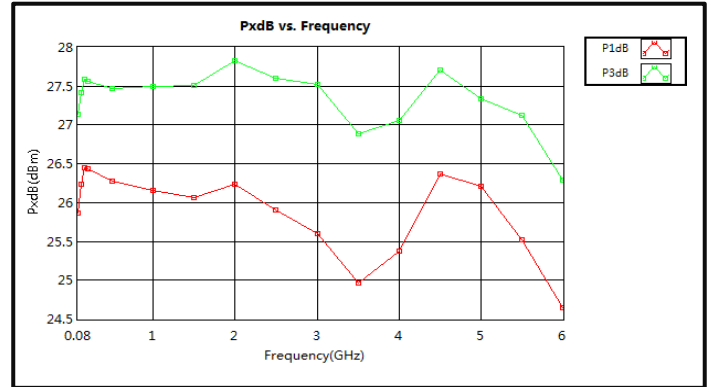

Saturated Power vs. Frequency

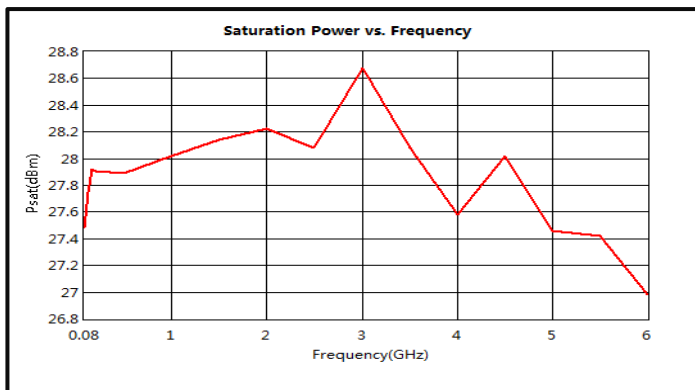

OIP3 vs. Frequency

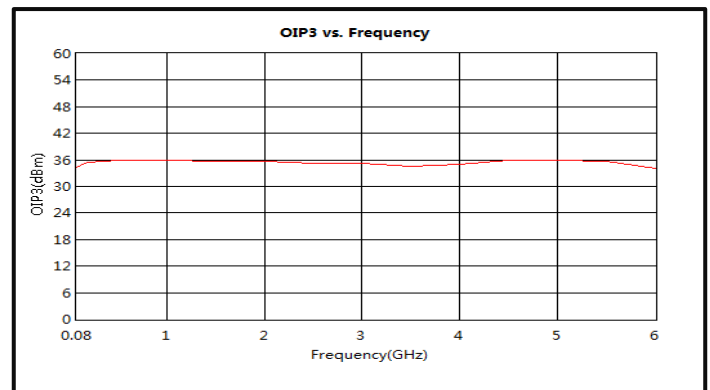

Noise Figure

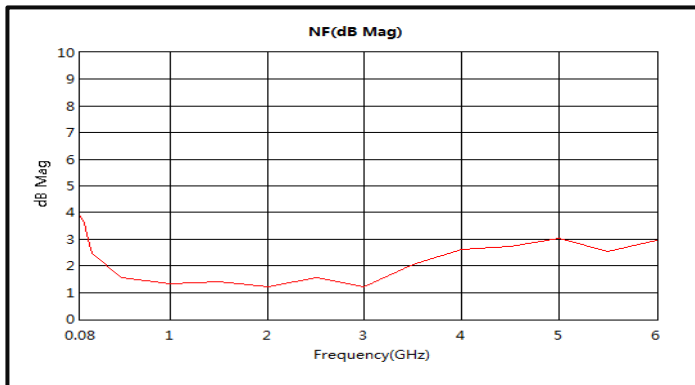

Pout vs. Pin

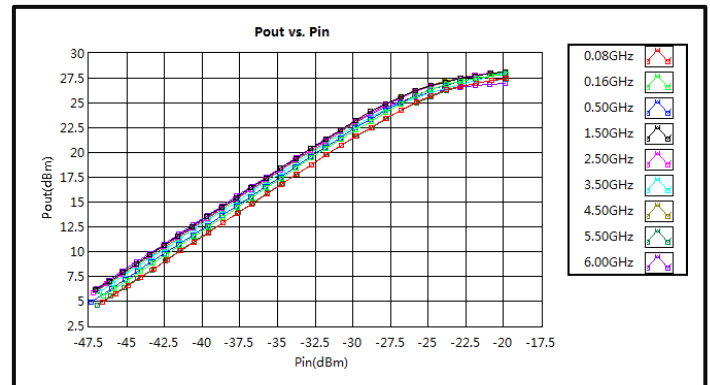

Typical Performance Plots

2nd Harmonic Wave Output Power

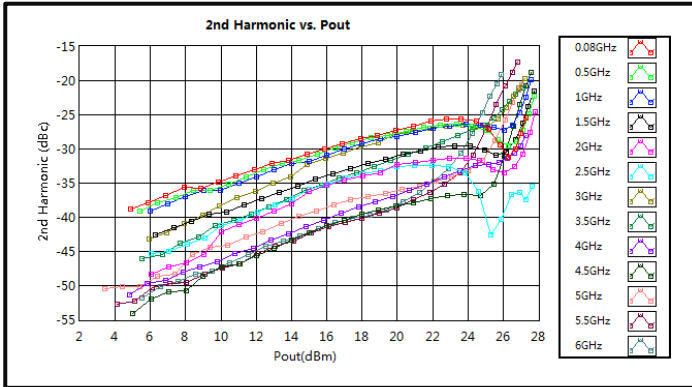

3rd Harmonic Wave Output Power

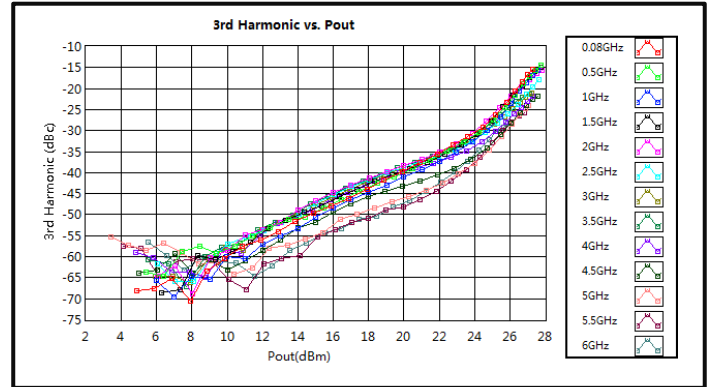

4th Harmonic Wave Output Power

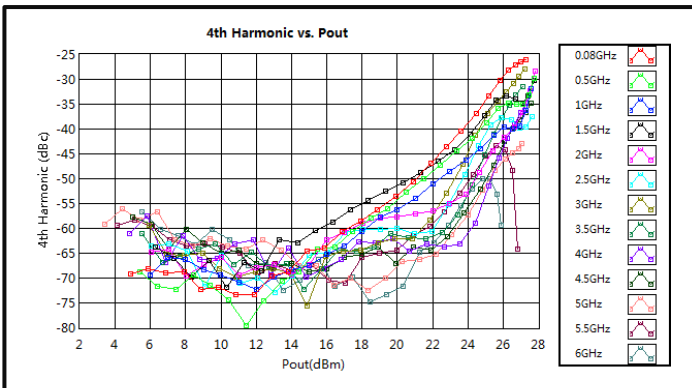

**Outline Drawing**

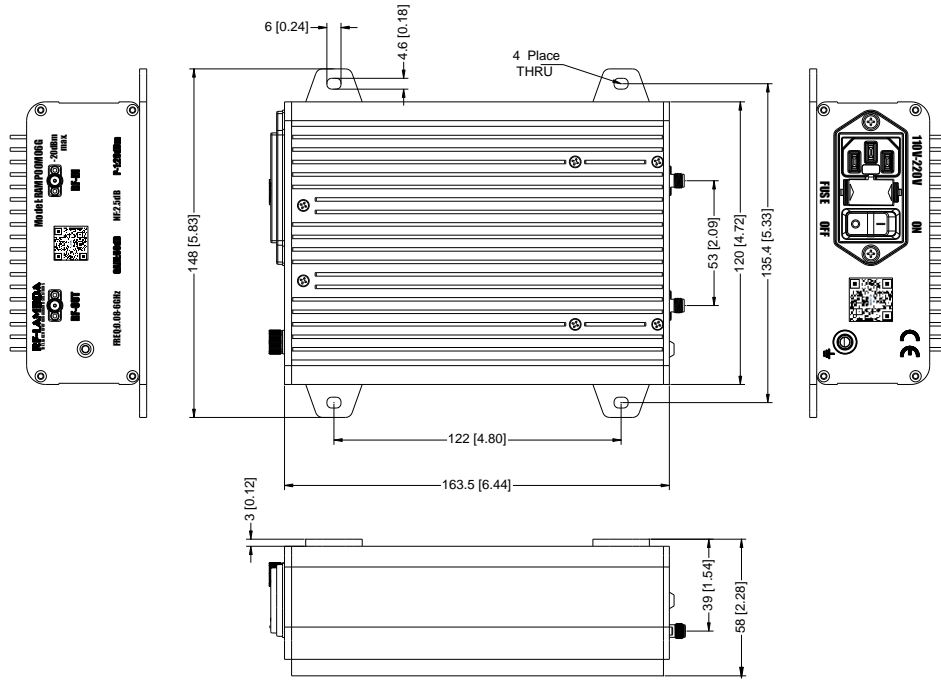

Notes:

1. All dimensions are in millimeters [inches].
2. Standard torque wrench must be used to secure RF connectors.

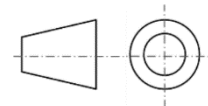

Additional Information

Documentation	Webpage
ESD Policy	<a href="https://rflambda.com/pdf/rflambda_esd_control.pdf">https://rflambda.com/pdf/rflambda_esd_control.pdf</a>
Heatsink Lookup Specifications	<a href="https://rflambda.com/search_heatsink.jsp">https://rflambda.com/search_heatsink.jsp</a>
Connector Torque Specifications	<a href="https://www.rflambda.com/pdf/Torque_Specifications.pdf">https://www.rflambda.com/pdf/Torque_Specifications.pdf</a>
Random Vibration Test Standard	<a href="https://www.rflambda.com/pdf/rflambda_random_vibration_MIL-STD-202G.pdf">https://www.rflambda.com/pdf/rflambda_random_vibration_MIL-STD-202G.pdf</a>

**Ordering Information**

Part Number	Modification	Description
RAMP00M06G	Standard	0.08GHz-6GHz AC Low Noise Amplifier

**Amplifier Use**

Ensure that the amplifier input and output ports are safely terminated into a proper 50 ohm load before turning on the power. Never operate the amplifier without a load. A proper 50 ohm load is defined as a load with impedance less than 1.9:1 or return loss larger than 10dB relative to 50 Ohm within the specified operating band width.

Power Supply Requirements

Power supply must be able to provide adequate current for the amplifier. Power supply should be able to provide 1.5 times the typical current or 1.2 times the maximum current (whichever is greater).

In most cases, RF - Lambda amplifiers will withstand severe mismatches without damage. However, operation with poor loads is discouraged. If prolonged operation with poor or unknown loads is expected, an external device such as an isolator or circulator should be used to protect the amplifier.

Ensure that the power is off when connecting or disconnecting the input or output of the amp.

Prevent overdriving the amplifier. Do not exceed the recommended input power level.

Adequate heat-sinking required for RF amplifier modules. Please inquire.

Amplifiers do not contain Thermal protection, Reverse DC polarity or Over voltage protection with the exception of a few models. Please inquire.

Proper electrostatic discharge (ESD) precautions are recommended to avoid performance degradation or loss of functionality.

What is not covered with warranty?

Each RF - Lambda amplifier will go through power and temperature stress testing. Since the die, ICs or MMICs are fragile, these are not covered by warranty. Any damage to these will NOT be free to repair.

**Important Notice**

The information contained herein is believed to be reliable. RF-Lambda makes no warranties regarding the information contained herein. RF-Lambda assumes no responsibility or liability whatsoever for any of the information contained herein. RF-Lambda assumes no responsibility or liability whatsoever for the use of the information contained herein. The information contained herein is provided "AS IS, WHERE IS" and with all faults, and the entire risk associated with such information is entirely with the user. All information contained herein is subject to change without notice. Customers should obtain and verify the latest relevant information before placing orders for RF-Lambda products. The information contained herein or any use of such information does not grant, explicitly or implicitly, to any party any patent rights, licenses, or any other intellectual property rights, whether with regard to such information itself or anything described by such information.

RF-Lambda products are not warranted or authorized for use as critical components in medical, life-saving, or life sustaining applications, or other applications where a failure would reasonably be expected to cause severe personal injury or death.