

## Ultra Wide Band AC Low Noise Amplifier 0.5GHz-80GHz



### Key Features

- Ultra Wide Band AC Power Amplifier
- Frequency Range 0.5-80GHz
- Output Power 12dBm Typical
- Noise Figure 7dB Typical

### Typical Applications

- Wireless Infrastructure
- Military and Aerospace
- Test and Measurement
- Radar and Satellite
- 5G LTE Communications

### Electrical Specifications, TA = +25°C

Parameter	Min.	Typ.	Max.	Min.	Typ.	Max.	Min.	Typ.	Max.	Min.	Typ.	Max.	Units
Frequency Range	0.5 ~ 5			6 ~ 40			41 ~ 70			71 ~ 80			GHz
Gain		38			35			37			22.2		dB
Gain Flatness		±2.0			±1.0			±1.0			±1.0		dB
Gain Variation Over Temperature (-40°C to +85°C)		±1.0			±1.2			±1.5			±1.5		dB
Noise Figure		4.5			4.3			5			10		dB
Input VSWR		1.8			1.4			1.5			1.5		: 1
Output VSWR		2			1.8			1.8			1.8		: 1
Output 1dB Compression Point (P1dB)		10.5			9.1			9			7.5		dBm
Saturated Output Power (Psat)		12.5			12.8			11			10		dBm
Output Third Order Intercept (OIP3)		20.3			20			19			17.3		dBm
Supply Current		0.5	0.7		0.5	0.7		0.5	0.7		0.5	0.7	A
Isolation S12		-70			-50			-30			-30		dB
Weight	2.5												lbs
Impedance	50												Ohms
Input / Output Connectors	1.00mm-Female												
Finish	Nickel Plated												
Material	Aluminum												
Package Sealing	Epoxy Sealed (Standard)												
	Hermetically Sealed (Optional)												

Absolute Maximum Ratings

Parameter	Value
Biasing	+240VAC
RF Input Power	Psat – Gain Sat

Note: Maximum RF input power is set to assure safety of amplifier. Input power may be increased at own risk to achieve full power of amplifier. Please reference gain and power curves.

Environmental Specifications and Test Standards

Parameter	Description
Operational Temperature	-40°C to +55°C (Case Temperature less than 85°C )
Storage Temperature	-50°C to +125°C
Thermal Shock	-40°C → +85°C (5 Cycles / 10 hours)
Random Vibration	MIL-STD-202G Table 214-I, Test Condition Letter C 1.5 Hours Per Axis
High Temperature Burn In	Temperature +85°C for 72 Hours
Shock	1. Weight >20g, 50g half sine wave for 11ms, Speed variation 3.44m/s 2. Weight <=20g, 100g Half sine wave for 6ms, Speed variation 3.75m/s 3. Total 18 times (6 directions, 3 repetitions per direction).
Altitude	Standard: 30,000 Ft (Epoxy Sealed Controlled Environment) Optional: Hermetically Sealed (60,000 ft. 1.0 PSI min)
Hermetically Sealed (Optional)	MIL-STD-883 (For Hermetically Sealed Units)

Ordering Information

Part Number	Description
RAMP05M80GC	0.5GHz-80GHz AC Low Noise Amplifier

**Amplifier Use**

Ensure that the amplifier input and output ports are safely terminated into a proper 50 ohm load before turning on the power. Never operate the amplifier without a load. A proper 50 ohm load is defined as a load with impedance less than 1.9:1 or return loss larger than 10dB relative to 50 Ohm within the specified operating band width.

**Power Supply Requirements**

Power supply must be able to provide adequate current for the amplifier. Power supply should be able to provide 1.5 times the typical current or 1.2 times the maximum current (whichever is greater).

In most cases, RF - Lambda amplifiers will withstand severe mismatches without damage. However, operation with poor loads is discouraged. If prolonged operation with poor or unknown loads is expected, an external device such as an isolator or circulator should be used to protect the amplifier.

Ensure that the power is off when connecting or disconnecting the input or output of the amp.

Prevent overdriving the amplifier. Do not exceed the recommended input power level.

Adequate heat-sinking required for RF amplifier modules. Please inquire.

Amplifiers do not contain Thermal protection, Reverse DC polarity or Over voltage protection with the exception of a few models. Please inquire.

Proper electrostatic discharge (ESD) precautions are recommended to avoid performance degradation or loss of functionality.

What is not covered with warranty?

Each RF - Lambda amplifier will go through power and temperature stress testing. Since the die, ICs or MMICs are fragile, these are not covered by warranty. Any damage to these will NOT be free to repair.

Typical Performance Plots

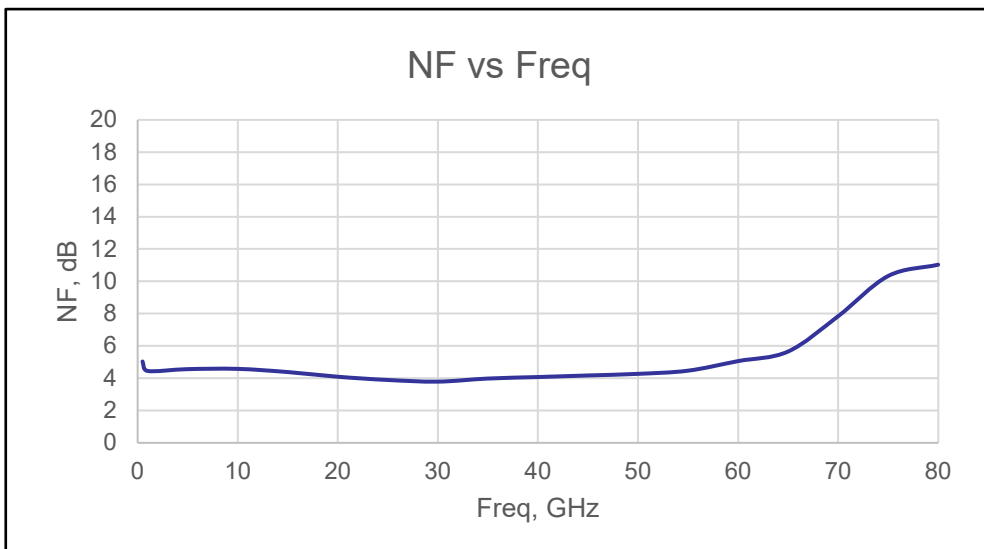
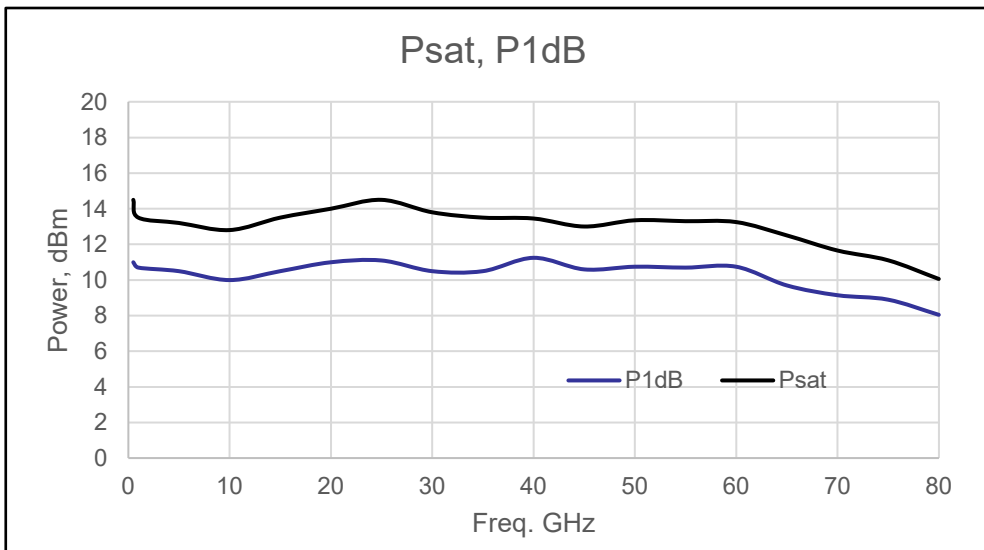
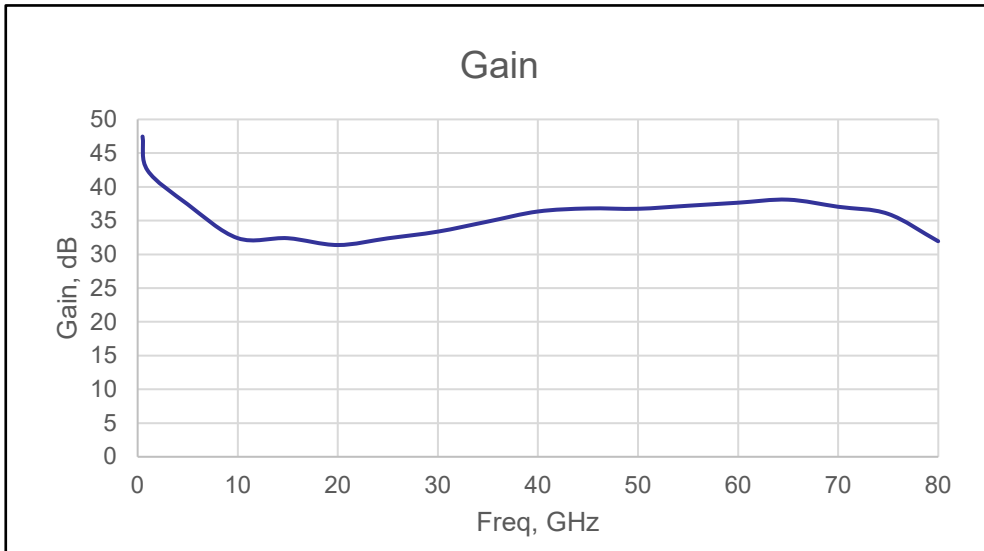

Outline Drawing

All Dimensions in mm [inches]

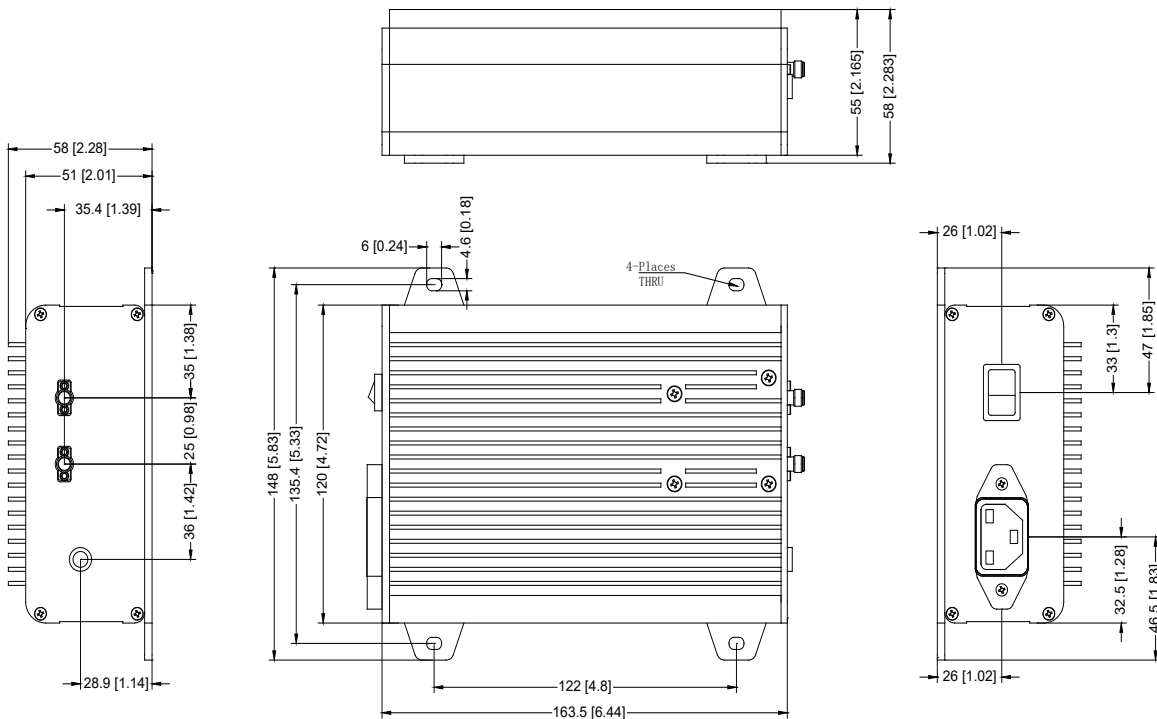

Notes:

- A 1.0mm adapter is strongly recommended.
- The RF connectors are NOT covered under warranty.
- Standard torque wrench must be used to secure RF connectors.



Important Notice

The information contained herein is believed to be reliable. RF-Lambda makes no warranties regarding the information contained herein. RF-Lambda assumes no responsibility or liability whatsoever for any of the information contained herein. RF-Lambda assumes no responsibility or liability whatsoever for the use of the information contained herein. The information contained herein is provided "AS IS, WHERE IS" and with all faults, and the entire risk associated with such information is entirely with the user. All information contained herein is subject to change without notice. Customers should obtain and verify the latest relevant information before placing orders for RF-Lambda products. The information contained herein or any use of such information does not grant, explicitly or implicitly, to any party any patent rights, licenses, or any other intellectual property rights, whether with regard to such information itself or anything described by such information. RF-Lambda products are not warranted or authorized for use as critical components in medical, life-saving, or life sustaining applications, or other applications where a failure would reasonably be expected to cause severe personal injury or death.