

80W Wideband EMC Benchtop Power Amplifier 26GHz-40GHz



Product Description

REMC26G40GL is a wideband EMC power amplifier with a frequency range of 26 to 40 GHz.

The power output of this amplifier is 49dBm typical. The typical small signal gain is 55dB with a flatness of ± 7 dB. This excellent performance is achieved through the use of GaN devices.

The power amplifier's input connector is 2.92mm-Male and the output is WR-28. This product has a calibration feature which enables customer to obtain great performance through time and temperature changes.

The operating temperature of this product is from 0°C to +50°C.

Features

- Wideband EMC Solid State Power Amplifier
- Small Signal Gain 55 dB Typical
- Output Saturation Power 49dBm Typical
- Supply Voltage 110/220 VAC
- 50 Ohm Matched Input/Output
- Over Temperature Protection
- Over Current Protection

Typical Applications

- Wireless Infrastructure
- Military and Aerospace Applications
- Test Instrumentation
- Radar Systems
- 5G Wireless Communications
- Microwave Radio Systems
- TR Modules
- Research and Development
- Cellular Base Stations

Electrical Specifications (T_A=+25°C)

Parameter	Min	Typ	Max	Units
Frequency Range	26		40	GHz
Small Signal Gain	48	55		dB
Gain Flatness		± 7.0		dB
Gain Variation Over Temperature (0°C to +50°C)		± 3.0		dB
Input VSWR		1.5		:1
Output 1dB Compression Point (P1dB)		46		dBm
Saturated Output Power (Psat)	47	49		dBm
Supply Current (220V AC)		4		A
IM3		-28		dBc
Power Added Efficiency (PAE)		15		%
Turn On/Off Speed (Switch Disable)	ON	100		ns
	OFF	100		ns
Turn On/Off Speed (Drain Disable)	ON	50		us
	OFF	200		us
Turn On/Off Speed (Gate Disable)	ON	1500		us
	OFF	200		us
Weight		58.5 Max.		lbs.
Impedance		50		Ohms
Input / Output Connectors	2.92mm-Male(Input)/WR-28 (Output) (E-Plane) (Input connector equipped with adapter to 2.92-Female) (H-Plane available with adapter)			
Package	3U Rack-mount/Tabletop Chassis			

Absolute Maximum Ratings

Parameter	Rating
Supply Voltage Range	90VAC to 264VAC
*RF Input Power (RFIN)	Psat – Large Signal Gain

Bias Up Procedure

1. Connect input and output with 50 Ohm source/load. (In band VSWR < 1.9:1 or >10dB return loss.)
2. Connect Power Cable
3. Turn On Back Panel AC Power Supply Switch
4. Press Front Panel Power Switch to Power Display

Bias Down Procedure

1. Press Front Panel Power Switch to Power Off Display
2. Turn Off Back Panel AC Power Supply Switch
3. Remove Power Cable (If Moving Equipment)
4. Disconnect input and output with 50 Ohm source/load. (In band VSWR < 1.9:1 or >10dB return loss.)

Environmental Specifications and Test Standards

Parameter	Description
Operational Temperature	0°C to +50°C (Case Temperature)
Storage Temperature	-40°C to +85°C
Thermal Shock	0°C → +50°C (5 Cycles / 10 hours)
**Random Vibration	MIL-STD-202G Table 214-I, Test Condition Letter C 1.5 Hours Per Axis
High Temperature Burn In	Temperature +50°C for 72 Hours
Shock	1. Weight >20g, 50g half sine wave for 11ms, Speed variation 3.44m/s 2. Weight <=20g, 100g Half sine wave for 6ms, Speed variation 3.75m/s 3. Total 18 times (6 directions, 3 repetitions per direction).
Altitude	Standard: 30,000 Ft (Epoxy Sealed Controlled Environment) Optional: Hermetically Sealed (60,000 ft. 1.0 PSI min)
Hermetically Sealed (Optional)	MIL-STD-883 (For Hermetically Sealed Units)

*Maximum RF input power is set to assure safety of amplifier. Input power may be increased at own risk to achieve full power of amplifier. Please reference gain and power curves.

**For vibration testing details please see additional information section.

Typical Performance Plots

Gain @ +25°C

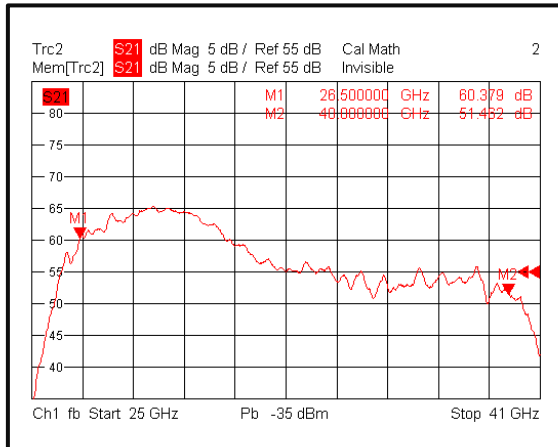

Input VSWR @ +25°C

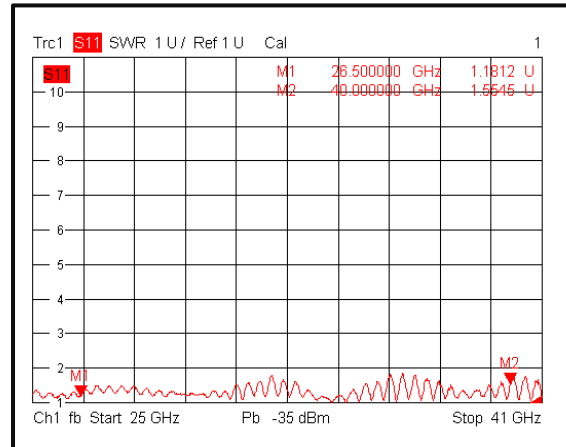

Isolation @ +25°C

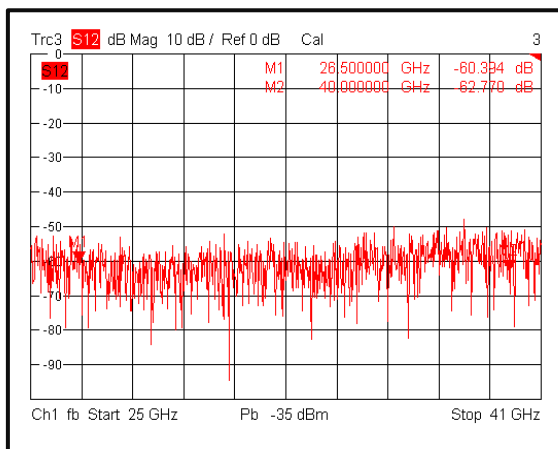

Note: Small signal VNA measurements include attenuators to protect equipment

Typical Performance Plots

Gain vs. Output Power CW

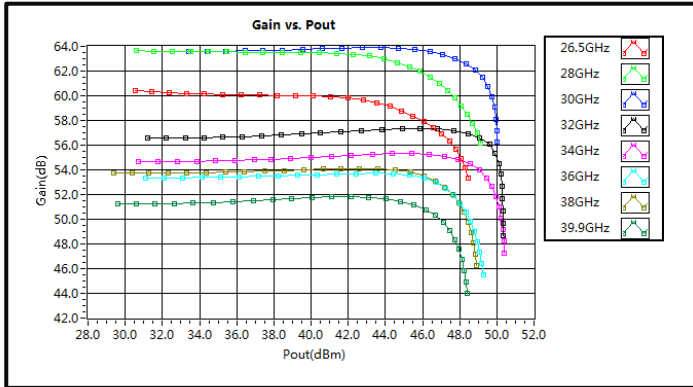

PndB vs. Frequency CW

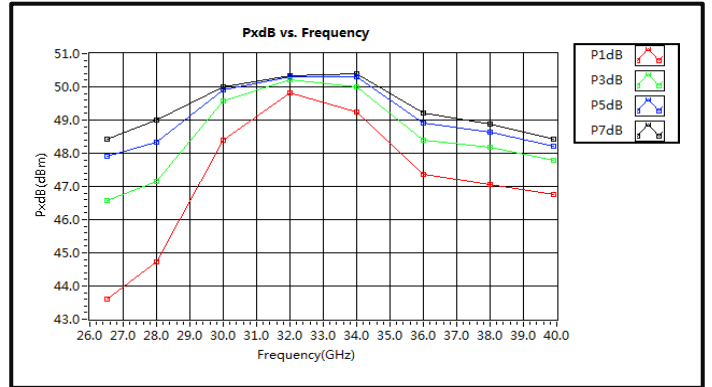

Saturation Power vs. Frequency CW

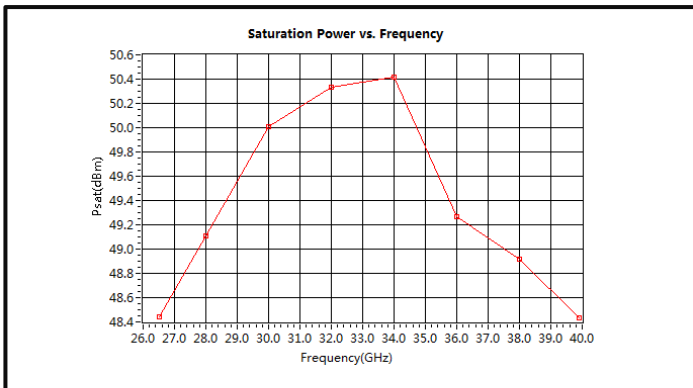

Pout vs. Pin

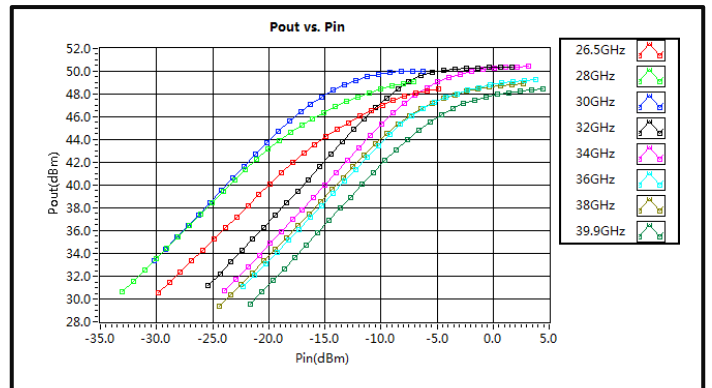

Typical Performance Plots

Left IM3 vs. Pout

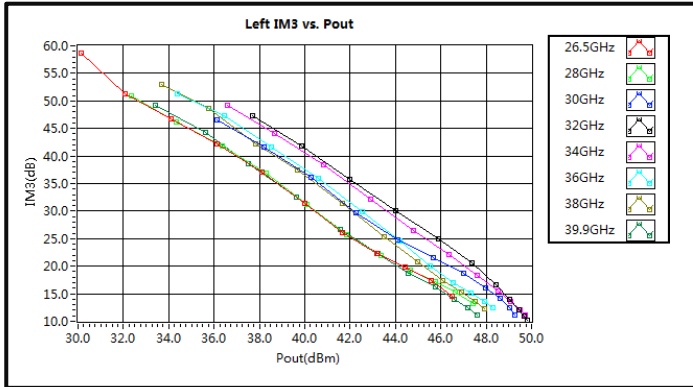

Right IM3 vs. Pout

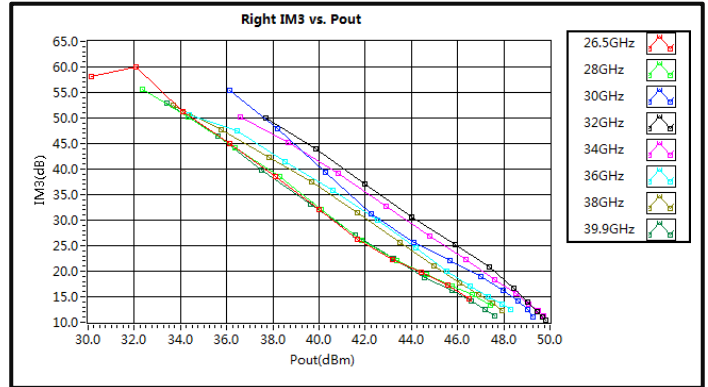

Delta IM3 vs. Pout

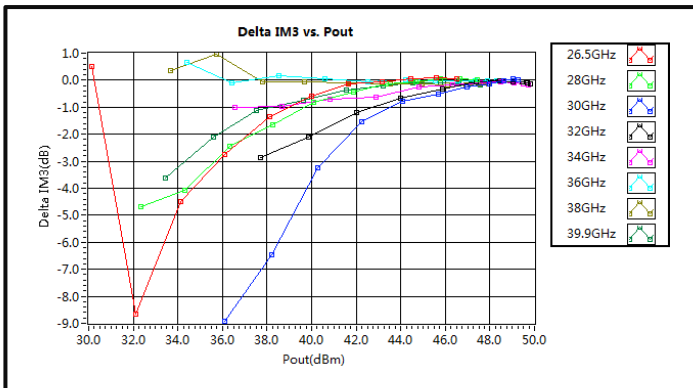

Note: IM3 test performed with 1MHz tone spacing

Typical Performance Plots

The RF Switch Off Time is 100 ns @+25°C



The RF Switch On Time is 100 ns @+25°C

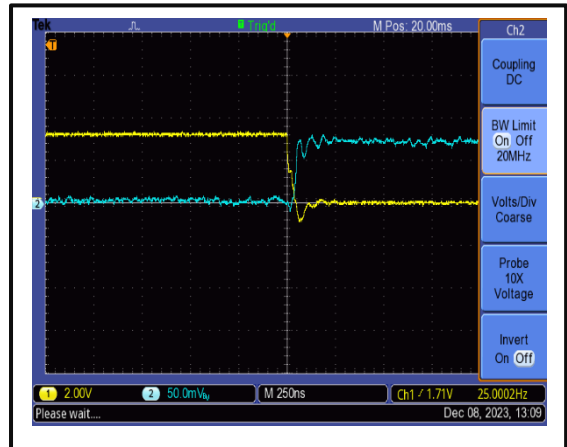

Switch control port: D-sub 15 PIN #10(Switch Disable) .
The yellow curve is the switch control signal, the blue curve is RF output envelope.

The Drains Closure Time is 200 us @+25°C

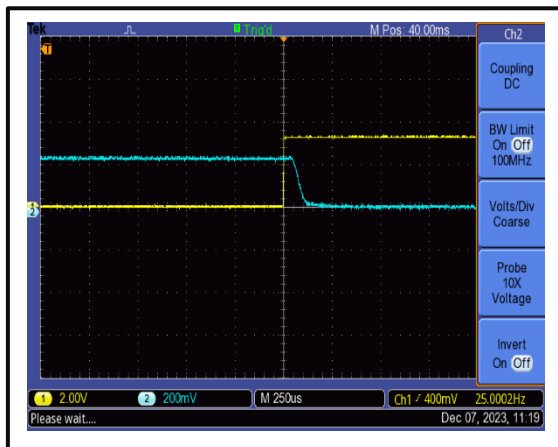

The Drains Open Time is 50 us @+25°C

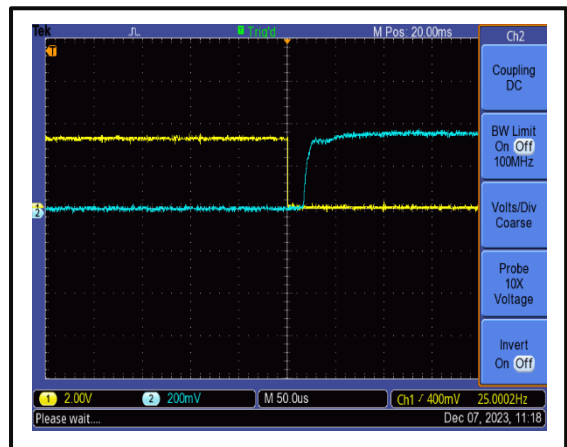

The drain control port: D-sub 15 PIN #3(Drain Disable).
The yellow curve is the drain control signal, the blue curve is RF output envelope.

The Gates Closure Time is 200 us @+25°C

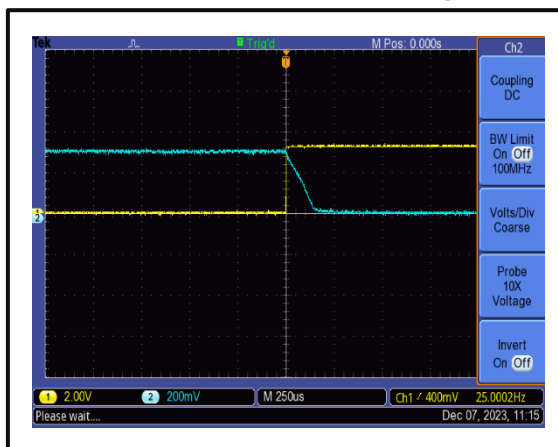

The Gates Open Time is 1500 us @+25°C

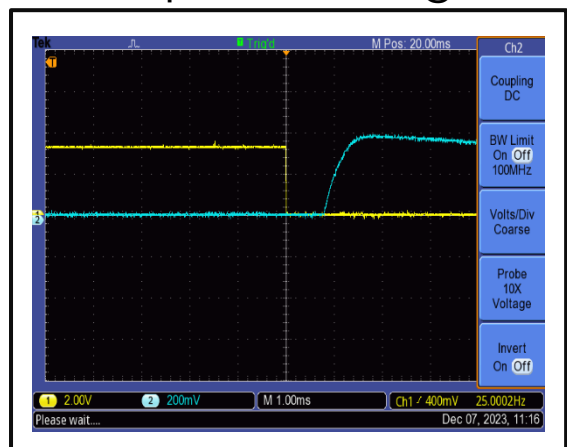

The gate control port: D-sub 15 PIN #2 (Gate Disable).
The yellow curve is the gate control signal, the blue curve is RF output envelope.

EMC Equipment Specifications

Front Panel

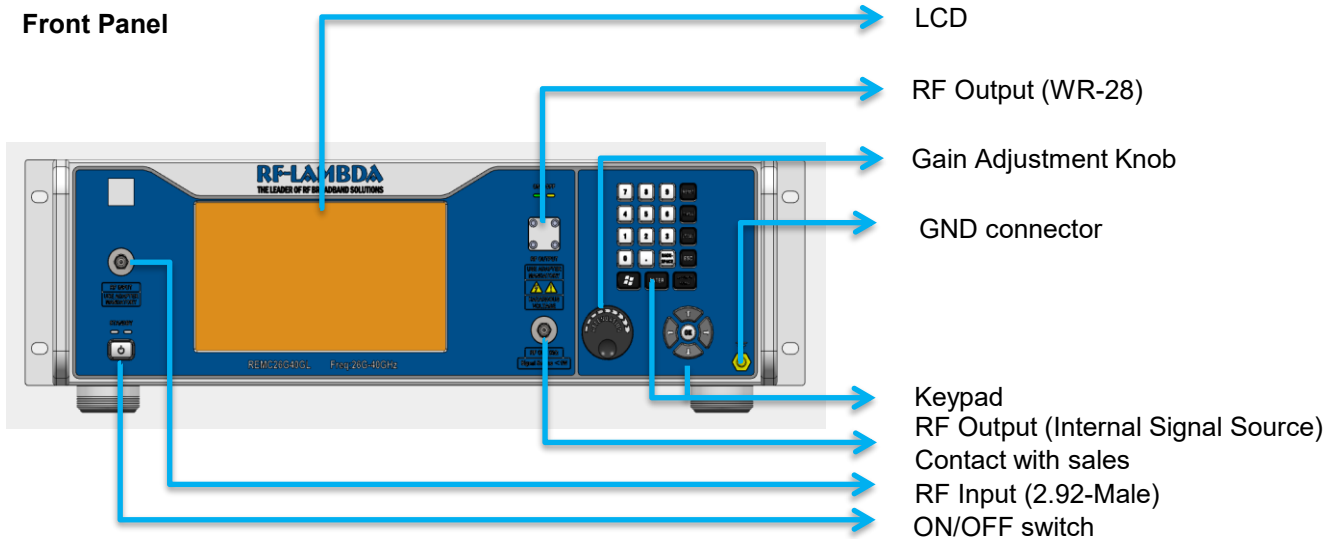

Rear Panel

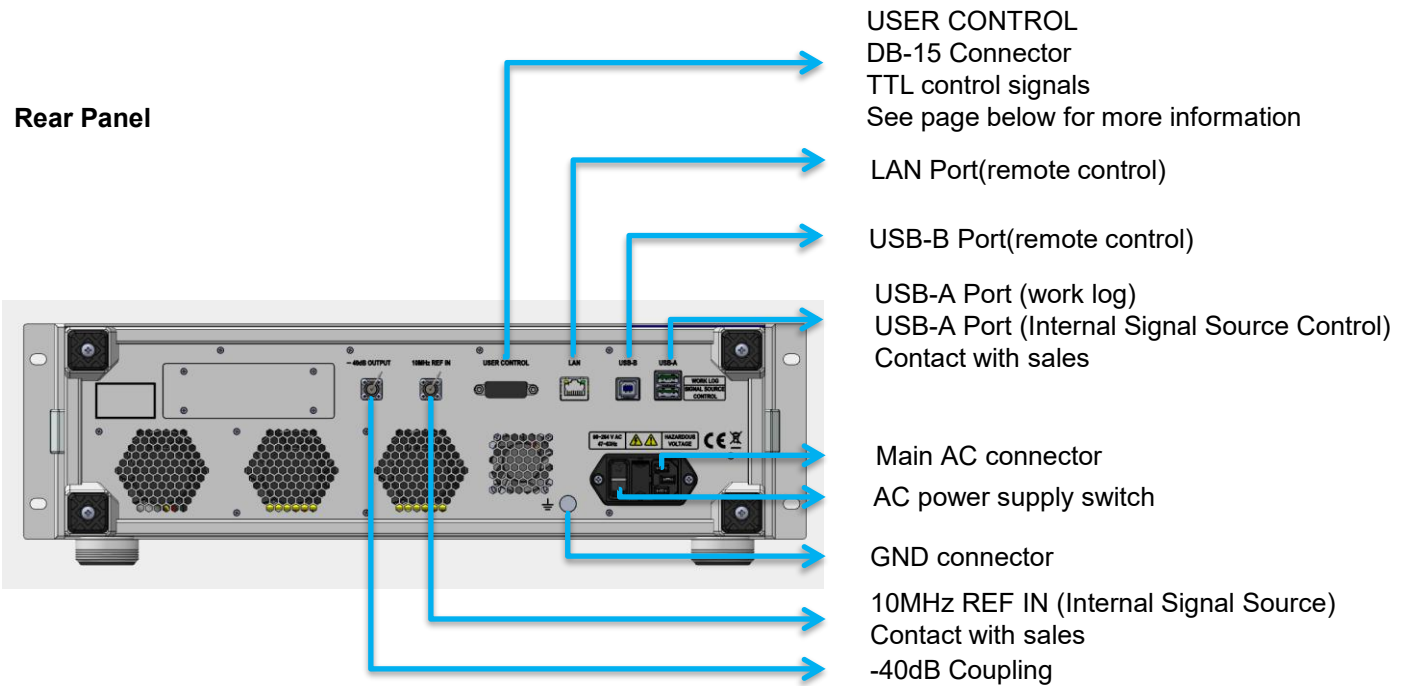

Front Panel LCD Screen Display

Switching On The Instrument

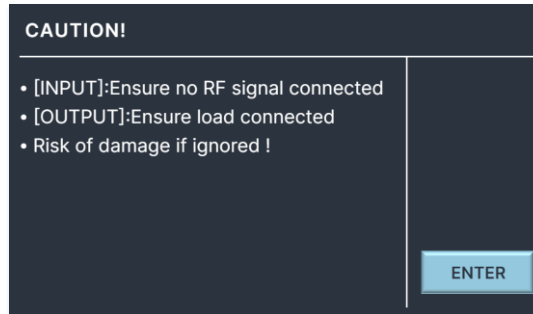
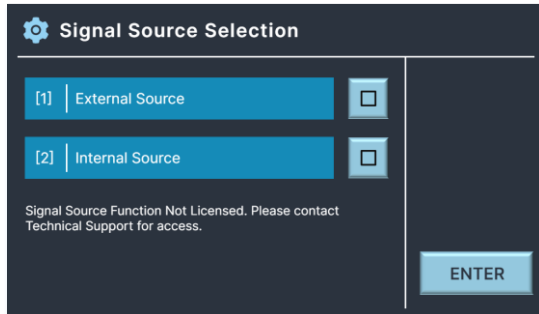

Please follow the instructions on the front panel LCD screen after switching on the power. Press “ENTER” on keypad to continue.(Default to external source)

Self Calibration Screen

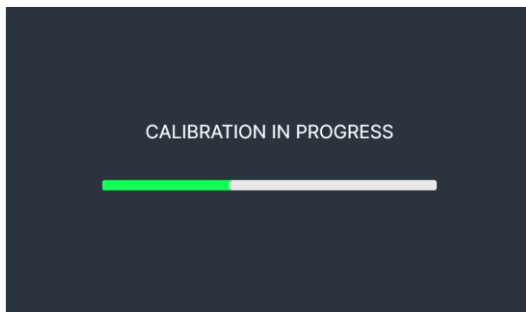

Calibration is may be recommended.

*Please turn OFF RF input power, and terminate the RF output port while applying calibration function.

Instrument Protection Alarms

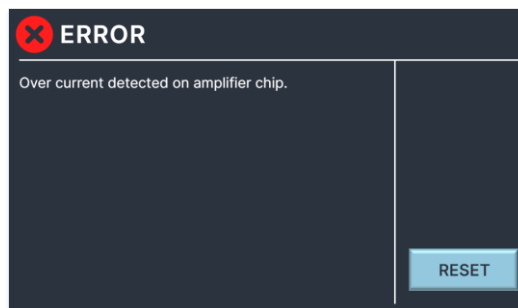
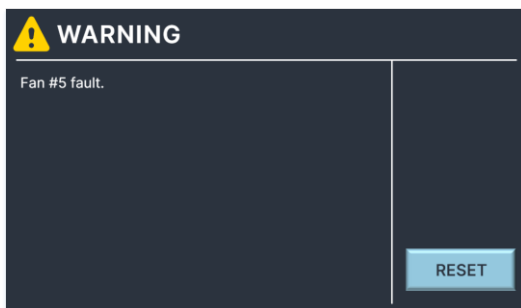

The front panel LCD screen will display the error code or error message when instrument self protection is triggered. Front panel alarm indicator will light up.

To eliminate the error code, press “RESET” on front panel keypad to reboot the instrument and clear the alarms. If error code can not be eliminated after reboot, please contact support@rflambda.com

Front Panel LCD Screen Function

Instrument Status Display Page

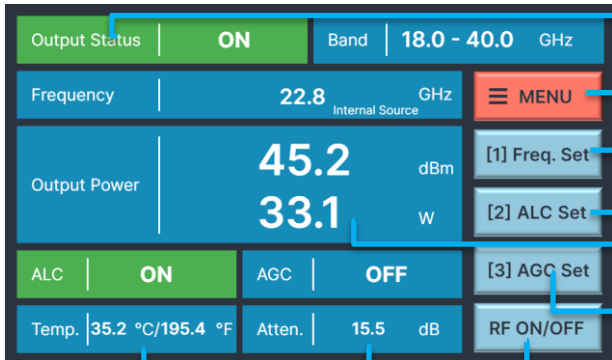

- Indicates instrument RF output status. It will display: ON or OFF
- Press "Menu" on keypad to enter instrument functions selection menu
- RF input signal frequency (For illustrative purposes only)
- ALC mode, power lock
- Instrument RF output power (For illustrative purposes only)
- AGC mode, this function is invalid
- Switches On or Off for instrument RF output port
- RF output attenuation (Change with adjustment knob)
- Instrument temperature (For illustrative purposes only)

Instrument Function Selection Page

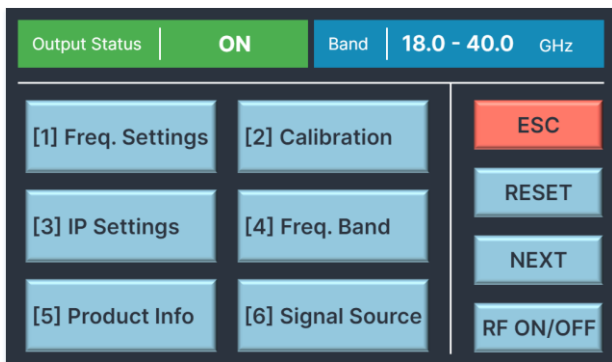

- To enter this function selection page, press "Menu" on front panel keypad while the instrument is showing the status page. Press the corresponding number on front panel keypad to select:
- "[1] Freq.Settings" enters RF input signal frequency
 - "[2] Calibration" the calibrate key is invalid
 - "[3] IP Settings" enters IP display page
 - "[4] Freq.Band" select current RF frequency range
 - "[5] Product Info" displays product information
 - "[6] Signal Source" select Internal or External Source

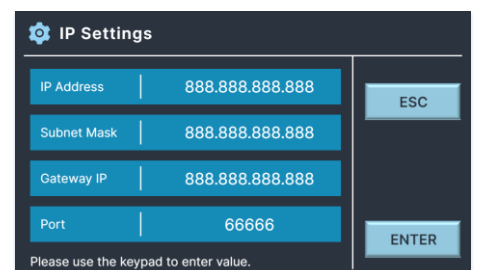
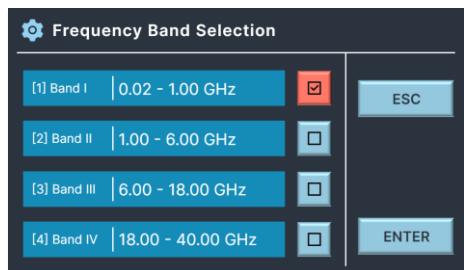
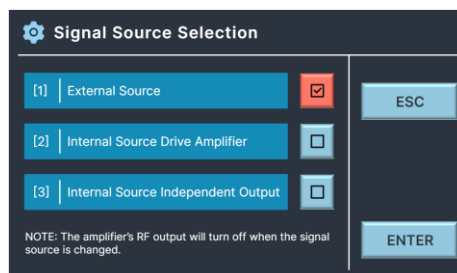
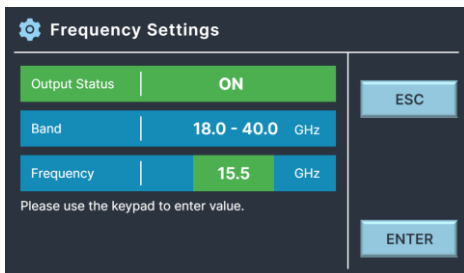

All action functions will ask for confirming execution when selected from function selection menu.

- Note1: The data shown here is just for presentation.
- Note2: Internal Signal Source need contact with sales

Protection Connector Table

Female D-Sub is on the housing
The mating Male part number: 172-E15-103R001

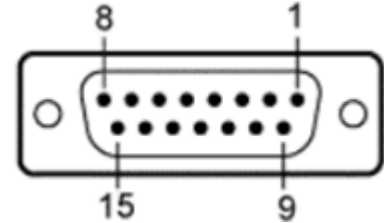

Pin #	Name	Function	Initial State	Description	Applied
1	Reset	Control	HIGH	Resets PA when logic <u>LOW</u> is applied for five more seconds and released	Yes
2	Gate Disable	Control	LOW	Applying logic <u>HIGH</u> disable gates of amplifiers	Yes
3	Drain Disable	Control	LOW	Applying logic <u>HIGH</u> disable drains of amplifiers	Yes
4	RF Input Over Drive	Indicator	LOW	Pin will be latched to logic HIGH when input signal is over limit	Yes
5	Temp Over	Indicator	LOW	Pin will be latched to logic HIGH when amplifier is driven over temperature	Yes
6	Current Over	Indicator	LOW	Pin will be latched to logic HIGH when drain current limit is reached	Yes
7	ID Imbalance	Indicator	LOW	Pin will be latched to logic HIGH when an imbalance in the drain current of the combining branches occurs	Yes
8	PA Off Alarm	Indicator	LOW	Pin will be latched to logic HIGH when any of the protection limit is reached	Yes
9	Fan Alarm	Indicator	LOW	Pin will be latched to logic <u>HIGH</u> when Fan limit is reached	Yes
10	RF Input Switch	Control	LOW	Applying logic HIGH turns OFF RF front-end switch to terminator	Yes
11	VSWR	Indicator	LOW	Pin will be latched to logic HIGH when output reflection is over limit	Yes
12	Fixed Attenuation 10dB	Control	LOW	Applying and holding logic HIGH to enable 10dB fixed attenuation	Yes
13	Fixed Attenuation 20dB	Control	LOW	Applying and holding logic HIGH to enable 20dB fixed attenuation	Yes
14	+5V	Power Supply	+5V	+5V DC is supplied for reference (200mA)	Yes
15	GND	Ground	GND	Ground	Yes

Notes:

- HIGH/LOW voltages are standard TTL signals 0.0V-0.8V = LOW. 2.8V-5V = HIGH.

Outline Drawing

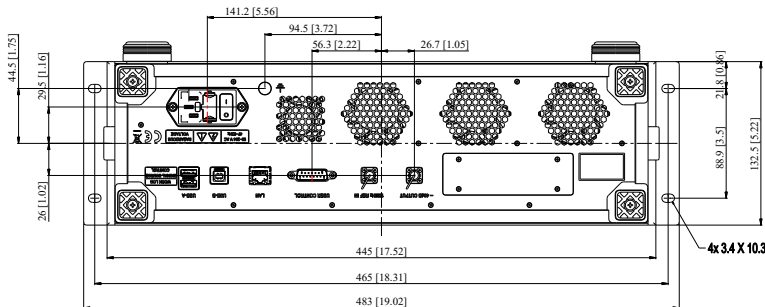
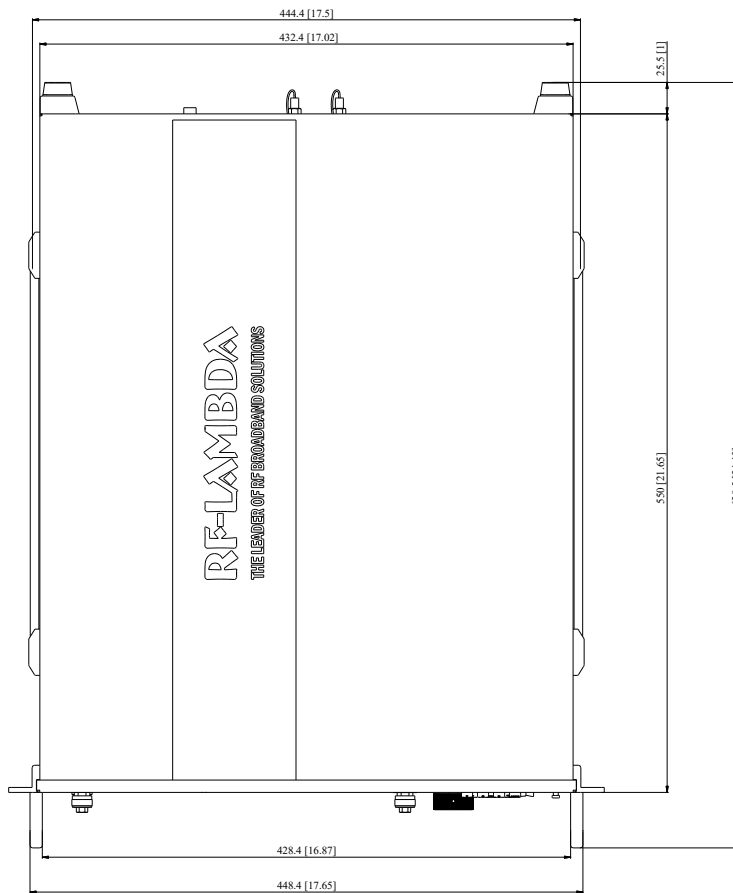
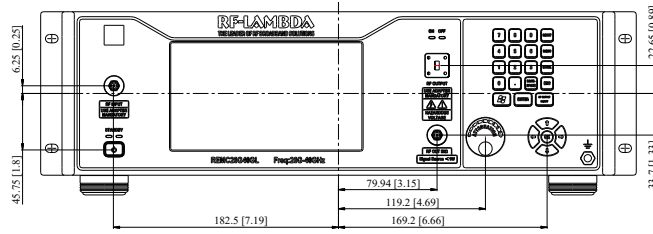

Notes:

1. Package Material: Aluminum
2. Finish: White Paint
3. All dimensions are in millimeters [inches].
4. Standard torque wrench must be used to secure RF connectors.

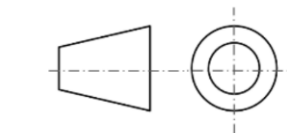

Packing List

ID	Description	QTY
1	Fig a. AC power supply line(Consult Sales)	1
2	Fig b. Adapter(RFCARAKFKF)	1
3	Fig c. Waveguide to coaxial adapter (RFA28E0COAL) (Consult Sales)	0
4	Fig d. Waveguide twist (RFWTWWR28) (Consult Sales)	0



Fig a.



Fig b.



Fig c.



Fig d.

Part Number	Modification	Description
REMC26G40GL	Input connector 2.92-Female and Output connector WR-28	26GHz-40GHz Wideband EMC Benchtop Power Amplifier

Amplifier Use

Ensure that the amplifier input and output ports are safely terminated into a proper 50 ohm load before turning on the power. Never operate the amplifier without a load. A proper 50 ohm load is defined as a load with impedance less than 1.9:1 or return loss larger than 10dB relative to 50 Ohm within the specified operating band width.

Power Supply Requirements

Power supply must be able to provide adequate current for the amplifier. Power supply should be able to provide 1.5 times the typical current or 1.2 times the maximum current (whichever is greater).

In most cases, RF - Lambda amplifiers will withstand severe mismatches without damage. However, operation with poor loads is discouraged. If prolonged operation with poor or unknown loads is expected, an external device such as an isolator or circulator should be used to protect the amplifier.

Ensure that the power is off when connecting or disconnecting the input or output of the amp.

Prevent overdriving the amplifier. Do not exceed the recommended input power level.

Adequate heat-sinking required for RF amplifier modules. Please inquire.

Amplifiers do not contain Thermal protection, Reverse DC polarity or Over voltage protection with the exception of a few models. Please inquire.

Proper electrostatic discharge (ESD) precautions are recommended to avoid performance degradation or loss of functionality.

What is not covered with warranty?

Each RF - Lambda amplifier will go through power and temperature stress testing.

Since the die, ICs or MMICs are fragile, these are not covered by warranty. Any damage to these will NOT be free to repair.

Important Notice

The information contained herein is believed to be reliable. RF-Lambda makes no warranties regarding the information contained herein. RF-Lambda assumes no responsibility or liability whatsoever for any of the information contained herein. RF-Lambda assumes no responsibility or liability whatsoever for the use of the information contained herein. The information contained herein is provided "AS IS, WHERE IS" and with all faults, and the entire risk associated with such information is entirely with the user. All information contained herein is subject to change without notice. Customers should obtain and verify the latest relevant information before placing orders for RF-Lambda products. The information contained herein or any use of such information does not grant, explicitly or implicitly, to any party any patent rights, licenses, or any other intellectual property rights, whether with regard to such information itself or anything described by such information.

RF-Lambda products are not warranted or authorized for use as critical components in medical, life-saving, or life sustaining applications, or other applications where a failure would reasonably be expected to cause severe personal injury or death.